

JPE 5-4-7

## Development of a Welding Machine System Using Brown Gas by Improved Water Electrolyzation

Yong-Kyun Lee\*, Sang-yong Lee\*, Byung-Hwan Jeong\*, Hyung-Soo Mok\* and Gyu-Ha Choe†

†\*Dept. of Electrical Engineering, Konkuk University, Korea

### ABSTRACT

Throughout the world, studies on the water energization are currently under way. Of those, Brown gas, which is generated through the electrolyzation of water and is a mixed gas of the constant volume of 2 parts hydrogen to 1 part oxygen, has better characteristics in terms of economy, energy efficiency, and environmental affinity than those of acetylene gas and LPG (Liquefied Petroleum Gas) used for existing welding machines. This paper analyzes the characteristics of Brown gas and presents methods for increasing the generating efficiency of Brown gas by designing a power supply to deliver power to a water-electrolytic cell and designing a cylindrical electrode to improve the efficiency of the electrolyzer needed for water electrolyzation. Based on the above the methods, a welding machine using Brown gas is developed. And the generation efficiency of Brown gas is measured under different conditions (duty ratio, frequency and amplitude) of supplied power.

**Keywords:** Brown gas, water electrolyzation, the generating efficiency of Brown gas, designing a power supply, designing a cylindrical electrode

### 1. Introduction

Brown gas is a mixed gas which has a constant volume ratio of 2 parts hydrogen to 1 part oxygen resulting from the electrolyzation of water. It has better characteristics in terms of economy, energy efficiency, and environmental affinity than acetylene gas and LPG (Liquefied Petroleum Gas), which are used for existing welding machines. Specifically, it has the features of implosion, complete combustion and environmental affinity. When burned, Brown gas implodes because its volume is larger than the

mixed gas of Hydrogen and Oxygen before burning. So, Brown gas is safer than acetylene or LPG (Liquefied Petroleum Gas) as kept or used for welding or other applications.

Moreover, during burning, Brown gas is completely combusted without additional oxygen. (Adding additional oxygen creates pollutants affecting the air quality.) Thus, Brown gas could be used in an airtight space such as an enclosed room without threatening the operator's safety. Hence, the use of Brown gas as a substitutive energy is gradually increasing in many industrial fields.

Currently, many studies focusing on the chemical analysis of electrolysis, the V-I characteristics of hydrogen-oxygen gas generators and the generating efficiency of gas are actively in progress. Conventional

Manuscript received January 28, 2005 ; revised Sep. 9, 2005

†Corresponding Author: ghchoe@Konkuk.ac.kr

Tel: +82-02-450-3486, Fax: +82-02-447-9186

\*Dept. of Electrical Eng. Konkuk Univ.

water electrolysis equipment is powered by a direct voltage source for a hydrogen-oxygen gas generator.

However, the weight and volume of the transformer are greater than those of a general transformer. As a result, its performance and efficiency were unacceptable. In this paper, a welding machine using Brown gas consisting of a water electrolysis system utilizing a pulse power supply is developed to provide high performance and efficiency. And the generating efficiency of Brown gas is measured under different conditions (duty ratio, frequency and amplitude) of supplied power

## 2. The Electrolysis of Brown Gas

General electrolysis of water requires a voltage source. An electrolytic cell system consists of two metal plates which are difficult to oxidize, an electrolyte, distilled water and a voltage source. Because the decomposition of water ( $H_2O$ ) is very difficult at low voltage, potassium hydroxide (KOH) is used as an electrolyte to cause a catalytic reaction. Fig. 1 shows a diagram of water electrolysis. The electrolyte (KOH) dissolved in the water becomes an ion as follow.



During the reaction, the electrolytes of KOH are decomposed into  $K^+$  cations and  $OH^-$  anions and then try to go to negative and positive electrodes respectively. Since  $K^+$  is reactive to water, it must be kept away from the air in the laboratory because even water moisture in the air can cause oxidation. Thus, the free  $K^+$  cation causes water to oxidize immediately on contact, re-forming itself as potassium hydroxide. In the oxidation process, electrons are removed from the molecules being oxidized, so the KOH now has its full set of electrons. The  $K^+$  rips off a hydrogen cation ( $H^+$ ) from the  $H_2O$ , leaving an  $OH^-$  for itself.

The resulting  $H^+$  heads for the cathode to pick up an electron to become a full mono-atomic hydrogen atom (H) and then the  $OH^-$  anion is left alone while the  $K^+$  cation and the  $H^+$  cation complete their part of the redox reaction.

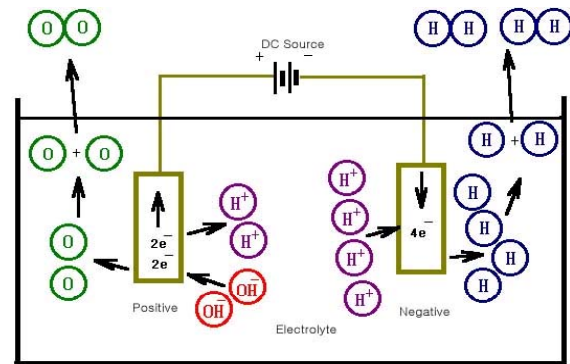
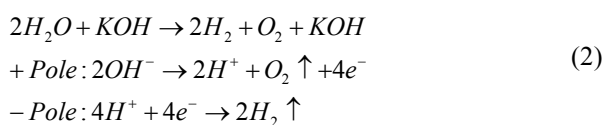

Fig. 1 Diagram of water electrolysis

The  $OH^-$  moves toward the positive plate of the anode. When the  $OH^-$  reaches the anode, it is oxidized (stripped of two electrons, turning  $H^-$  into  $H^+$ ) and split into a mono-atomic oxygen atom (O) and a hydrogen cation ( $H^+$ ). The hydrogen cation immediately leaves the vicinity of the anode on its way to the cathode. Often, it will not go directly to the cathode, it will combine with an  $OH^-$  and reform into water, then the water will be split again by  $K^+$ , when the  $H^+$  arrives at the cathode, it picks up the electron it needs to become a proper mono-atomic hydrogen atom (H). The process is actually more complicated than the reactions of the electrolytic cell just described above because there are many interactions between the  $H_2O$ , KOH,  $OH^-$ ,  $K^+$ ,  $H^+$  and any impurities in the solution. Obviously, the reactions of oxidation and deoxidization create the same quantity of electricity. The chemical equation is defined as follows.

For the relation between electric charge and its chemical equivalent, the electrolysis of water is defined by Faraday's law of electrolysis

- (1) The weight of a given element liberated at an electrode during electrolysis is directly proportional to the quantity of electricity.
- (2) When the same quantity of electricity passes through solutions of different electrolytes, the weight of the substances liberated at the electrodes is directly proportional to their equivalent weight.

During electrolysis the rate of output is a function of the molecular weight of the product, its valence and the total current passing through the electrolytic cell. One Faraday is the amount of current that will produce one gram mole of a product with a valence. To split water into  $H_2$  and  $O_2$ ,  $H_2O$  takes two Faradays per mole, and two

Faradays will convert 18 grams (about 0.635 oz) of water into hydrogen-oxygen gas. Two Faradays are equivalent to 193038 Coulombs. This equals the product of the current through the cell in amps and the time in seconds that the current is applied. Thus, the output of a hydrogen-oxygen gas generator operating at 5 amps would be 1.678 grams of gas per hour [2]. As mentioned above, the chemical equivalent is calculated with atomic weight and valence and we get the electrical energy through the chemical equivalent[5].

### 3. Generating Efficiency of Brown Gas

The generating efficiency of Brown gas is affected by complex elements such as the waveform, frequency, offset and amplitude of the supply voltage and current; and the size, number and distance between electrodes as shown in Fig. 2. The efficiency is defined by the total amount of gas vs. input power and the amount of gas consisting of mono-atomic molecules vs. total gas. Generally, for the efficiency of electrical phenomenon such as welding, electrolysis goes better when the pulse voltage or current waveform is supplied with an electrolyzer rather than by a direct waveform. In this paper, to analyze the effect of electrical elements, current waveform control is provided by a pulse power supply and total amount of gas vs. input power is measured to assess efficiency. The pulse power supply controls amplitude, offset, duty ratio and frequency and measures the average current as shown in Fig. 3. Fig. 4 shows the current controller of the pulse power supply. It consists of a PI controller, limiter, carrier generator and a PWM modulator.

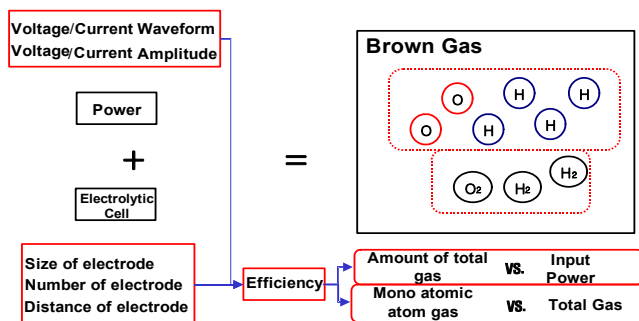

Fig. 2 Elements influencing the generating efficiency of Brown gas

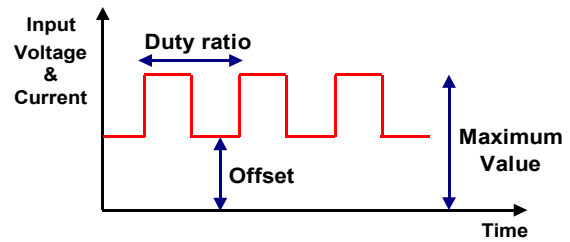

Fig. 3 Current controller waveform

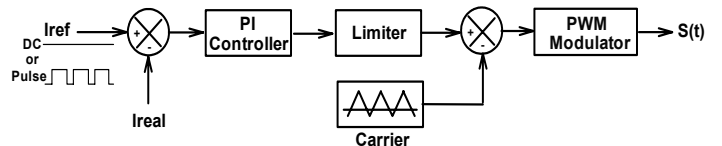

Fig. 4 Block diagram of current control

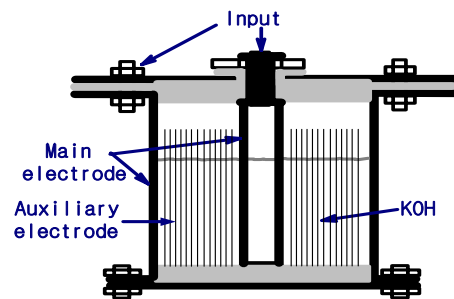

Fig. 5 Cross section of a cylindrical electrolytic cell

### 4. Generating Efficiency of Brown Gas

An electrolytic cell is used to electrolyze water and generate hydrogen-oxygen gas. Fig. 5 shows a cylindrical water electrolytic cell. The center pole is connected with the positive pole of the power supply and the shell pole is connected with the negative pole. In conventional schemes, the electrode form is a rectangular plane[7]. By designing a cylindrical water electrolytic cell with multi poles [3], we can increase the area of the electrode surface in the same volume, thus increasing the efficiency of the electrode construction. The electrode is made of stainless steel that is difficult to oxidize.

The diameter of the shell pole is fixed at 210[mm]. Auxiliary electrodes are designed as two types: either the same interval or the same volume as in Fig. 6. When the same current flows through each cylindrical electrolytic cell, Fig. 7 shows the amount of Brown gas generated as the input current is changed. In Fig. 7, the electrolytic cell with an identical interval of auxiliary electrodes generates

much more Brown gas than the electrolytic cell with the same volume.

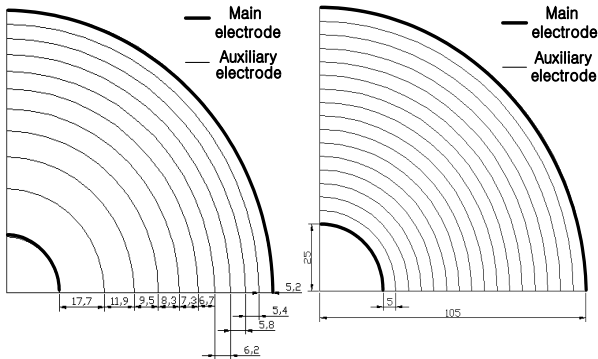

Fig. 6 Horizontal cross section of an electrolytic cell

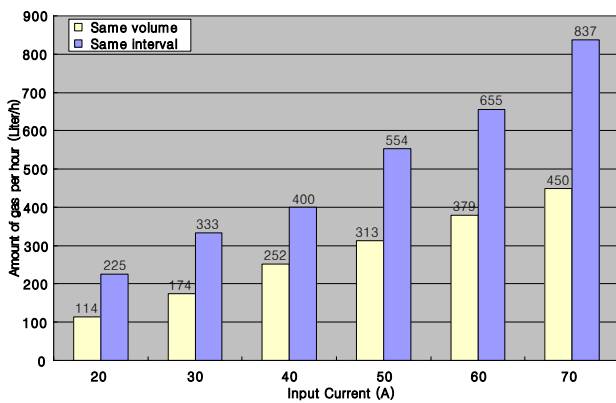

Fig. 7 Amount of Brown gas generated by input current

### 5. Structure of a Welding Machine System

As shown in Fig. 8, a general transformer is typically used as a power supply for electrolysis of water and diodes are used to change from AC voltage to DC voltage. As a power supply, general transformers are big and heavy; and since the diode rectifier is not a controllable device, the power supply can't control the voltage or current. But, in Fig. 9, the proposed power supply is a high frequency transformer which has the advantages of being light and small. Also, by adopting a full bridge inverter, the proposed power supply can control the voltage and the current. The principles for operating this power supply are as follows. First, the current is changed from a DC source to an AC source using a full bridge diode rectifier and the DC source is converted to a 10kHz AC source. Then, the

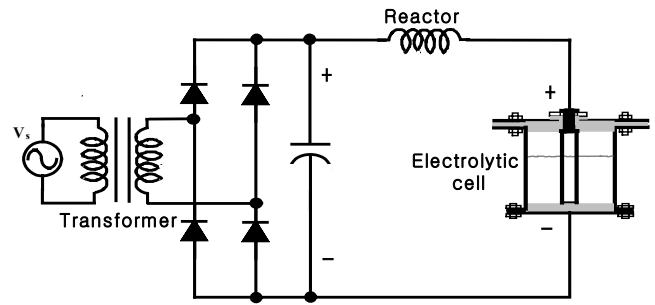

Fig. 8 Existing power supply

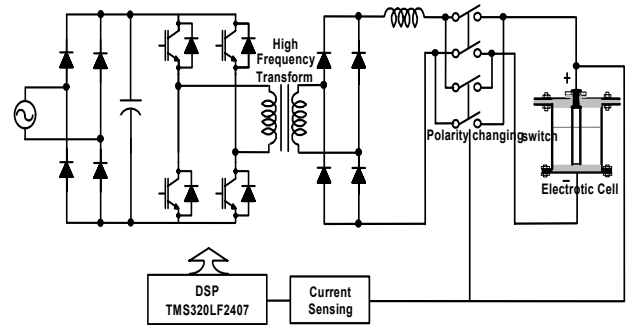

Fig. 9 Proposed power supply

voltage of the AC source is reduced by a high frequency transformer. This AC source is rectified to a DC source by using a fast recovery diode rectifier. The microcontroller of TMS320LF2407A was chosen to rapidly perform this function. An inverter in power supply is controlled by a current PI control PWM method<sup>[6]</sup>. To avoid anode oxidation of the electrolytic cell and increase electrolytic cell life, polarity changing switches periodically change the polarity of the supplied power. Based on the proposed power supply of Fig. 9, the welding machine using Brown gas is set up such as in Fig. 10. It consists of a water electrolytic cell, a pulse power supply, current sensors and a flame arrestor device. The cylindrical water electrolytic cell is used for maximum electrode area and a 25% potassium hydroxide (KOH) liquid is used as an electrolyte. Fig.11 shows a prototype of a welding machine using Brown gas.

### 6. Experiment Result

In this paper, a 25% potassium hydroxide (KOH) liquid is used. Tin, nickel, glass, copper and zinc are used to observe characteristics of welding. Current control is

Table 1 Test Condition

Input Voltage	AC 220V
Inverter Stack	5kVA
Switching Frequency	10kHz
HF transformer turn ratio	2:1
DC link Capacitor	44000uF
Reactor	1.2mH

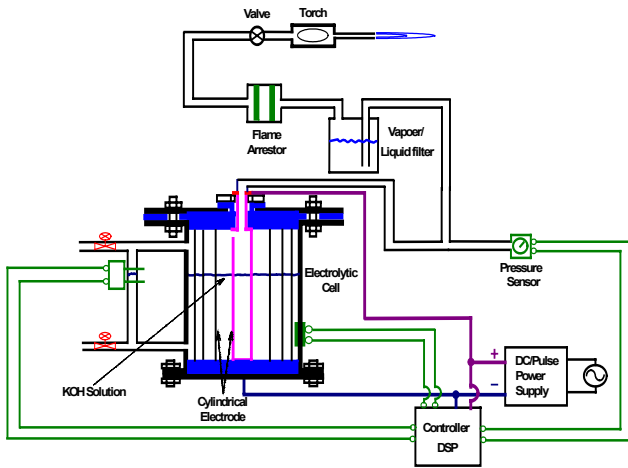

Fig. 10 Structure of a Brown gas welding machine

performed by frequency, amplitude and offset control. The amount of generated gas increases as the duty ratio increases and we fixed it at 75%. Generating amount of Brown gas during 1 hour is acquired Fig. 12 shows the waveform of the current reference and Fig. 13 shows the waveform of the output current and confirms longer rising and falling time than the reference because of the RC time constant of the water electrolytic cell. TABLE II shows the amount of gas generated increases as average current increases. But, the amount of generating gas is saturated at about 70[A]. However, the saturation point can be increased by using a higher frequency. Hence, to generate the maximum amount of gas at 75[A], a current of 400[Hz] should be supplied. When supplying pulse current, a much larger amount of gas is generated than when supplying DC current.

Fig. 14 shows the shape of the flame is long and thin at low gas pressure due to the implosion characteristics of Brown gas, which makes it possible to weld small material. Fig. 15 shows the welding flame characteristics of copper,

nickel, tin and zinc. Fig. 16 shows the welding temperature of each metal. It can be verified that flame temperatures and lightings are different for each material because of the thermonuclear reactions of each material. Welding with Brown gas does not leave any soot.

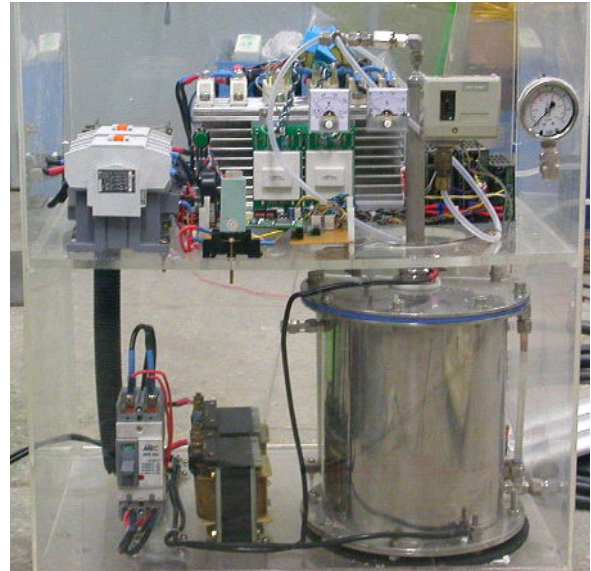

Fig. 11 Prototype of a welding machine using Brown gas

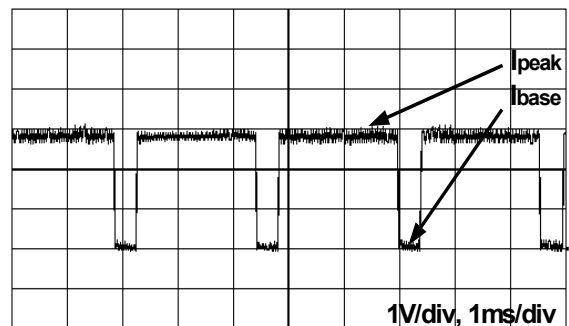

Fig. 12 Waveform current reference

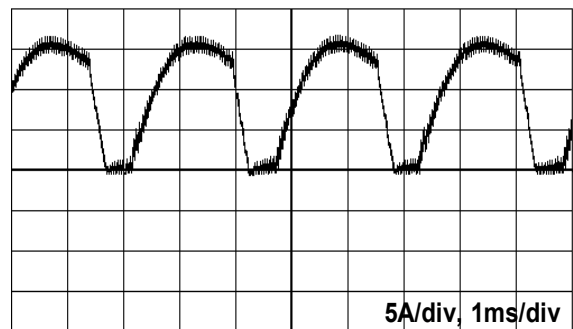

Fig. 13 Waveform output current

Table 2 Amount of gas generated as frequency and current level[ℓ/h] change

[A] \ [Hz]	DC	120	200	250	300	350	400
10[A]	67	72	70	69	50	57	50
15[A]	131	144	134	132	108	120	150
20[A]	192	234	211	193	203	192	231
25[A]	253	325	269	271	279	243	306
30[A]	317	373	341	340	333	324	361
35[A]	403	474	398	435	417	414	445
40[A]	469	509	473	493	476	478	509
45[A]	532	575	556	559	522	595	555
50[A]	607	641	637	597	594	626	631
55[A]	675	680	674	655	654	674	668
60[A]	758	770	721	673	711	714	716
65[A]	787	804	790	791	780	791	801
70[A]	810	841	856	856	860	885	877
75[A]	816	906	934	944	945	968	983

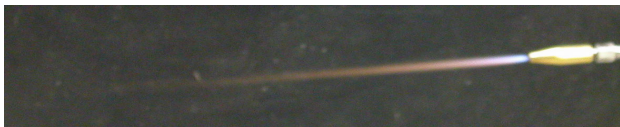

Fig. 14 Flame of a Brown gas welder

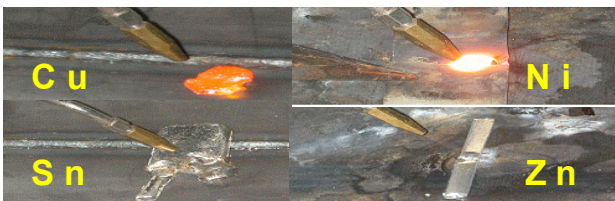

Fig. 15 Welding experiment

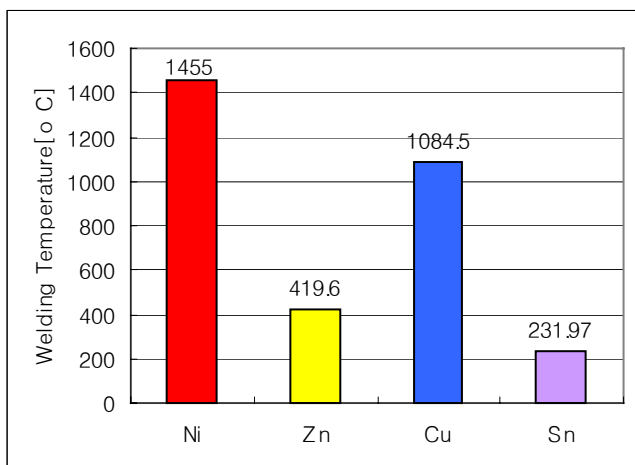

Fig. 16 Welding temperature of each metal

## 7. Conclusion

According to the welding experiment results, it is verified that Brown gas can be used for welding of non-metallic material and it has clean and various welding features. By the electrical characteristics, it could be confirmed that the amount of gas generated increases as current increases and becomes saturated at some point. The saturation point can be increased by increasing the current frequency. But the maximum efficiency of gas generation point is different from the maximum amount of gas point. Most users wish to use a welding machine that generates the maximum amount of gas when using the same water electrolytic cell. Therefore, it is desirable that Brown gas generator should be operated at a point of maximum gas generation by increasing the frequency of the current. More studies need to be done to improve the efficiency of maximum gas generation..

## Acknowledgements

This work was supported by a research fund provided by the Korea Science and Engineering Foundation from Sep. 1. 2000 to Aug. 31. 2003.

## References

- [1] S.D.Seul, "Inorganic Chemical Technology", DeaYoung, 1996, pp184~192.
- [2] George Wiseman, "Brown's Gas, Book1", Eagle Research, 1995.
- [3] Geoge Wiseman, "Brown Gas, Book1", Eagle Research, 1995, pp.1~4.
- [4] J.M.Lee, "A Study on the Water Electrolysis Equipment by Using Pulse Power Supply", KonKuk Univ. a master's degree paper, 1999, pp15~16.
- [5] Lerner Rita G, Trigg G, "Encyclopedia physis," VCH publishers, Inc, 1991, pp.272~273.
- [6] J. Holtz, "Pulsewidth Modulation-A Survey", IEEE. PESC.Pro. Rec., 1992 pp. 410~420.
- [7] A. Volanschi, "Microcavity Electrodes Used as Single-Nucleation Site Electrodes for the Electrolysis of Water", Sensors and Materials. Vol. 9. No. 4, 1997, pp.223~240.



machines using Brown gas.

**Yong-Kyun Lee** was born in Seoul, Korea, on August 7. He received a B.S. degree in electrical engineering from Konkuk University, Seoul, Korea where he is currently working toward an M.S. degree. His research interest is developing welding



algorithms of solar cell and photovoltaic systems.

**Sang-Yong Lee** was born in Hongsung, Korea on December 2. He received a B.S. degree in electrical engineering from Konkuk University, Seoul, Korea where he is currently working toward an M.S. degree. His research interest is MPPT



is currently working toward a Ph. D degree. Since 2005, he has been with Korea Electrical Engineering and Science Research Institute (KESRI), where he is currently a senior researcher at the energy conversion center. His current research interests are parallel operation of inverter systems and renewable energy power condition systems.

**Byung-Hwan Jeong** was born in Pohang, Korea. He received a B.S. degree in electrical engineering from Kyungsoong University Pusan, Korea, in 2001 and an M.S. degree in electrical engineering from Konkuk University, Seoul, Korea, where he



and Instrumentation Engineering as an assistant professor at Seoul National University of Technology, Seoul, Korea. Since 1997, he has been with the Department of Electrical Engineering, Konkuk University, Seoul, Korea. His research interests are in the fields of motor drives, electrical machines, PWM controls, and ac voltage regulators.

**Hyung-Soo Mok** was born in Cheonan, Korea. He received the B.S., M.S. and Ph.D. degrees from Seoul National University, Seoul, Korea, in 1986, 1988 and 1992, respectively. From 1992 to 1996, he worked in the Department of Control



Engineering, Oregon State University, Covallis. 1997 to 1998,

**Gyu-Ha Choe** was born in Pusan, Korea. He received the B.S., M.S. and Ph.D. degrees from Seoul National University, Seoul, Korea, in 1978, 1980 and 1986, respectively. From 1987 to 1988, he was a Visiting Scholar in the Department of Electrical

Visiting Professor at Virginia Polytech Institute & State University, Blacksburg, VA, 1998 to 1999, Konkuk University, Seoul, Korea Vice President, Jan. 2001 to Dec. 2001, The Korean Institute of Power Electronics Dean of Academic Affairs, 2002 to 2004, Auditor the Korean Institute of Power Electronics, Seoul, Korea, January 2004 – Dec. 2004, Head of EE Dept. Industry Graduate Konkuk University, Seoul, Korea, 2004 to present. Since 1980, he has been with the Department of Electrical Engineering, Konkuk University, Seoul, Korea, where he is a Professor and Dean of Academic Affairs. His research interests are in the fields of active power filters, PWM control, ac voltage regulators, inverter welding machines, photovoltaic systems and Brown gas welding machines.